

AB FRAMS TRYCKERI
VASA 1955

INSTRUCTION BOOK
FOR

Olympia

Marine Engines

FINSKA MOTORFABRIKS AB.

Vasa - Finland

Telegramadr. "Olympia"

CONTENTS

	Page
General specifications for OLYMPIA 1-cyl. engines types 50-KT, 36-A and EB	1
General specifications for OLYMPIA 2-cyl. engines types 2-F-45 and 2-Q-48	4
General principles for the management of the OLYMPIA marine engines	7
Instructions for starting	8
Control and management during running	9
Running-in a new engine	10
To stop the engine	11
Gearbox maintenance	11
Localizing and repairing of damages	13
Low effect	14
The engine stops while running	14
Guarantee and delivery terms	15

FINSKA MOTORFABRIKS A.B.

Vasa — Finland

General specification for OLYMPIA 1-cyl. engines type 50-KT, 36-A and EB

	50-KT	36-A	EB
Bore:	75 mm	85 mm	108 mm
Stroke:	110 »	134 »	150 »
Cubic Capacity:	0,485 ltr	0,76 ltr	1,37 ltr
Compression Ratio (kerosene):	4,2:1	4,16:1	4:1
» » (petrol):	6:1	6:1	6:1
Piston, cast iron:	74,94 mm	84,93 mm	107,93 mm
Piston Rings:	3 piston rings 75×3 mm	3 piston rings 85×5 mm	3 piston rings 108×6 mm
Connecting Rods:	Hammer forged, supplied with fixed white metal bearings	D:o	D:o
Crankshaft:	Hammer forged, toughhardened, located in 2 fixed mainbearings. Diameter of crankpin = 35 mm	D:o 42 mm	D:o 50 mm
Cylinder Block:	Cast iron, cylinder and upper crank case foundried in one piece	D:o	D:o
Cylinder Head:	Cast iron, detachable	D:o	D:o
Valves: Sidetype	Diameter of inlet valve stem — 0.040 9 —0.062 Ø of outlet valve stem = —0.080 9 —0.095	D:o —0.030 9 —0.050 —0.080 9 —0.095	D:o — 0.050 12 — 0.093 —0.050 12 —0.093

	50-KT	36-A	EB
Tappet clearances, inlet:	0,3 mm	0,3 mm	0,3 mm
» » outlet:	0,4 »	0,4 »	0,4 »
Outlet pipe:	does not belong to standard equipment	D:o	D:o
	Ø of pipe 1"	1¼"	1¼"
Lubrication.			
Lubricating System:	Splash lubrication	D:o	D:o
Oil sump capacity:	0,8 ltr	1,3 ltr	2,6 ltr
Lubricant:	Use an approved brand of engine oil. Viscosity during summertime (temp. at least + 10° C) SAE 30, wintertime (temp. below - 10° C) SAE 20	D:o	D:o
Cooling System.			
Type:	Saltwater cooling; water pump of piston type	D:o	D:o
Water pipe:	Does not belong to standard equipment		
	Ø of inlet pipe = 3/8"	3/8"	3/8"
	Ø » outlet » = 1/4"	1/4"	3/8"
Fuel System.			
Fuel:	Normal kerosene; start and heating by petrol. Equipped with a special cylinder head petrol can be used; increase of power in that case = 15 %	D:o	D:o
Fuel pump:	Is not used. The fuel to the carburettor by selfpressure. The bottom of fuel tank installed at least 200 mm above the carburettor when the boat is worked	D:o	D:o
Carburettor:	OLYMPIA 25 mm or SOLEX type 26 VN made of brass, supplied with needle valve	OLYMPIA 25 mm D:o	OLYMPIA 30 mm D:o
Ignition System.			
Type:	Magneto ignition Magneto brand SEM type E-IR-30 or BOSCH type MZ/JF 1-R-2	D:o SEM type EX-1R-30 BOSCH type MZ/JF 1AR5 with impulse starter and manual timing	D:o SEM type EX-1R-30 BOSCH type MZ/JF 1AR with impulse starter and manual timing
Sparking Plugs:	BOSCH M 45 T ₂ , CHAMPION C-7 or corresponding. Point gap 0,4 0,5 mm	D:o	D:o
Reverse Gear.			
Type:	Lamellatype; 2 lamellas 1 made of cast iron, 1 of steel	D:o, 5 lamellas, 3 made of cast iron, 2 of steel	D:o
	As engine lubricating system is splash lubrication, oil is not delivered from engine oil sump to gear oil sump. Change oil by changing oil in the engine using same brand and viscosity.	D:o. Every 100 hour press grease oil mixture into gear drum	D:o

General specification for OLYMPIA 2-cyl. engines type 2-F-45 and 2-O-48

	Type 2-F-45	Type 2-O-48
Bore:	75 mm	100 mm
Stroke:	110 »	126 »
Cubic Capacity:	1,06 ltr	1,98 ltr
Compression Ratio (kerosene):	4,26 : 1	4,12 : 1
D:o (petrol):	6,10 : 1	6,10 : 1
Pistons:	Cast iron, Ø 74,94 mm	Aluminum alloy Ø 99,91 mm
Piston Rings:	3 rings 75×3 mm compression	3 compression rings 100×3 mm 1 scraper ring 100×5½ mm
Connecting Rods:	Hammer forged, supplied with fixed white metal bearings	D:o, white metal bearings of shell type
Crankshaft:	Hammer forged, toughhardened, located in 2 fixed white metal mainbearings Diameter of crankpin = 42 mm	D:o, located in 2 white metal mainbearings of shell type. Ø = 60 mm
Cylinder Block:	Cast iron; cylinder and upper crankcase foundried in one piece	D:o; cylinder detachable from upper crankcase.
Cylinder Head:	Cast iron, detachable	D:o
Valves:	Sidetype; diameter of inlet valve stem = 9 -0,036 -0,050 Ø of outlet valve stem = 9 -0,080 9 -0,095	D:o; diameter of inlet valve stem = 10 -0,03 -0,05 Ø of outlet valve stem = 10 -0,080 10 -0,095

4

	Type 2-F-45	Type 2-O-48
Valves:	Diameter of inlet valve head larger than exhaust. Tappet clearance inlet = 0,3 mm Tappet clearance outlet = 0,4 mm	D:o D:o D:o
Outlet pipe:	Does not belong to standard equipment. Ø of pipe = 1¼"	D:o Ø of pipe = 1½"
Lubrication.		
Lubricating System:	Pressure lubrication by gear type pump. Normal oil pressure = 1-1½ kg/cm² indicated on engine oil pressure gauge	D:o
Oil sump capacity:	3½ ltr	D:o 4 ltr
Lubricant:	Use an approved brand of engine oil. Viscosity during summertime (temp. at least + 10° C) SAE 30, wintertime (temp. below + 10° C) SAE 20	D:o
Oil pressure adjustment:	By reduction valve outside the engine	D:o
Cooling System.		
Type:	Saltwater cooling; water pump of piston type	D:o. The temperature adjustable by a separate arrangement and thermometer
Water pipe:	Does not belong to standard equipment Ø of inlet pipe = ¾" Ø of outlet pipe = ¼"	D:o D:o D:o
Fuel System.		
Fuel:	Normal kerosene; start and heating by petrol. Equipped with a special cylinder head, petrol can be used; increase of power in that case = 15 %	D:o

5

Type 2-F-45

Type 2-O-48

Fuel Pump:	Is not used. The fuel to the carburettor by selfpressure. The bottom of fuel tank to be installed at least 200 mm above the carburettor when the boat is worked.	D:o
Carburettor:	OLYMPIA 25 mm or SOLEX type 26 VN, made of brass, supplied with needle valve	OLYMPIA 35 mm or AMAL 35 mm, made of brass, supplied with needle valve.
Ignition System.		
Type:	Magneto ignition. Magneto brand SEM type EX-2R-30 or BOSCH type MZJF 2AR5; manual timing and impulse starter. Contact breaker point gap 0,3—0,4 mm	D:o
Sparking Plugs:	18 mm, BOSCH M 45 T ₂ CHAMPION C-7 or corresponding. Point gap 0,4—0,5 mm	
	18 mm, BOSCH M 45 T ₁ , CHAMPION 8-Com. or corresponding. Point gap 0,6—0,8 mm	
Reverse Gear.	Lamella type; 5 lamellas, 3 made of cast iron, 2 of steel. Gear feeded with oil from engine oil sump. No special lubrication necessary	
Type:		

General principles for the management of the OLYMPIA marine engines

An OLYMPIA-motor is designed for the safest possible running under all conceivable conditions. Every motor wants, however, a certain degree of supervision and control for getting a function without disturbances. The following details are important in this respect:

- Lubrication oil of prescribed viscosity and of an approved brand is to be used. Change oil in accordance with our instructions.
- Follow the evidence of the dip-stick regarding the amount of oil in the crankcase. Do not fill up more oil than the max. mark on the dip-stick indicates, never let the oil-level sink below the min. line.
- Check the oilpressure with the aid of the manometer, when the engine is warm. Do not run, if the pressure sinks below $\frac{1}{2}$ kg/cm², only stop and look for, what is wrong.
- Start the engine and run it warm on petrol, then switch over to kerosene.
- Never race the engine, when it is cold.
- Keep the boat that dry, that the engine is never lying in water. If you get water into the engine for some reason, change the oil and check that all the water has been removed.
- Do not run the engine, if you are aware that something is wrong, only repair the fault already in an early stage.

— Follow our advices, not other «experts».

If there is a risk for frost, take the following precautions:

- Open the watertaps of the waterpump and the cylinder.
- Check that all the water has really been let out by cleaning the taps with wire or such. Mud and slime may choke up them and prevent all the water from flowing off.

Instructions for starting

- Check the oil level and the fuel before starting, set the gear-shaft on neutral.
- Open the petroltap, or if there is no special petroltank, fill up the carburettor with petrol. (We recommend a special petroltank.)
- Unscrew the needle valve $\frac{1}{2}$ — $\frac{3}{4}$ round, give the motor one petrolsup through the supcups in the cylinderhead (provided that the motor is cold; a warm motor with petrol in the carburettor needs no sups), open the gas-throttle for about $\frac{1}{4}$ speed and set the magneto on late ignition (the controlarm backwards).
- After frost the water outlet pipe must be inspected to see that it is not frozen; otherwise there are risks that the cylinder will burst.
- Start the motor by the aid of the handle.

After starting the motor the number of revolutions is increased to 400—500 r. p. m., that is the gashthrottle is set on barely $\frac{1}{2}$ speed, the ignition is changed to early (the controlarm forewards) and the gearshaft is pulled on slowly but firmly, without touching the gashthrottle nor the needlevalve.

If the speed is to be increased, the needlevalve is set on $\frac{3}{4}$ —1 rev. and the gashthrottle is opened more.

When the motor has run about 5 min., switch over to kerosene; the needlevalve is choked till the motor has slowed down a little. In this way the lowest possible fuel consumption is gained at normal marchspeed.

Control and management during running

Check the oilpressure with aid of the manometer, which should say about $1\frac{1}{2}$ kg/cm².

Check that the cooling waterpump takes water and that this really circulates through the waterjacket of the cylinder. If the out-take is in the boatside, the control is easiest done by looking if the water is pumped out, in other case by opening the water outlettap of the cylinder.

Type 2-O-48 is supplied with a gear for regulation of the temperature of the coolingwater. When running, the thermometer should indicate about $+80^{\circ}$ C. In order to attain this temperature, proceed as follows:

Open the tap of the gascase, which regulates the waterintake to the outletpipe. Adjust the tap, situated at the right side of the waterpump, so that it is pointing at V. Continue running with this adjustment and check the temperature. When the thermometer indicates about 75° , the tap should be switched towards K so that it is set between V and K. If the temperature should show a tendency to decrease, switch the tap towards V, if the temperature is increasing above 80° , the tap should be switched a little towards K. You soon learn from experience how the tap has to be set for attaining the temperature of 80° .

The piston on the waterpump has to be greased about once every hour with aid of the grease cup on the pump. Even the rubberseal of the reversecouplingbearing is to be greased and the inner stembearing of the propellershaft by respective grease-cups about once every hour.

Running-in a new engine

The treatment of a new engine during the first 30 running-hours may be of crucial importance for the motor's term of life and its function in the future. During this period the first wear of the movable parts of the motor is happening. If this wear is allowed to happen slowly, without unnecessary strain, the result will be good.

That is why, during the first 30 running-hours, you ought not to take out full effect from the motor, only be content with $\frac{1}{2}$ speed. Never race the motor when cold, rather not even when it is run-in, but absolutely not when it is new!

Change the oil after the first 30 running-hours and rinse the motor just as well with one of the special oils available in the shops for this purpose. Clean the oilsump thoroughly with a rag (not waste cotton) after the rinsing, before filling up the new oil. During the first running-hours there may eventually be detached some left behind rests of castsand and microscopical metalsplinters from the movable parts of the engine. Mixed up together with lubricating-oil the restparticles form an effective grinding instrument, that wears the motor very quickly. As these particles are heavier than the oil, they sink to the bottom of the oilsump and are not removed just by the change of oil, only they have to be removed with a rag.

Pull the screwnuts of the cylinderhead tighter at least once during the running-in period, as the cylinderhead gasket will be pressed together considerably during this first time. The pullingtighter has to be done preferably when the motor is warm in order to get an affective packing and to spare gasket.

During running-in period no top-oil is needed.

After the running-in period the oil has to be changed about every 50th running-hour.

To stop the engine

About 5 min. before you are going to stop the engine definitely, switch to petrol. During this time the motor consumes the kerosene in the carburettor and is replaced with clean petrol. In this way the start following is made easier.

At the same time the watertap on the gascase is to be closed in order to stop the watersupply to the outletpipe. This is most important on account of the following:

If the tap is not shut, but water is pumped through the outletpipe until the motor stops, there will be water left in the pipe. The water is turned into watersteam because the outletpipe is heated. The steam, that usually is salty on account of the salinity of the water, rises upwards and gets away via the outlet channels and the exhaust valves to the compression-chamber. If there are any exhaust valves open, the steam streams past the heated valves with a strong corrosion as a result. Already after a short time's using the valves may, because of this, close imperfectly and the imperfection will quickly grow worse under running. The result will be bad compression and reduced effect. Thus always shut the watertap to the outletpipe in due time!

The motor is stopped by closing the needlevalve. If there is no special petroltank, the fuelsupply has to be choked. The engine stops, as the fuel in the carburettor is consumed.

Most magnetos are supplied with an arrangement for short-circuit of the current. By stopping the motor in this way fuel is spared, but in this case there must be a special petroltank and you must switch to petrol before the motor is stopped.

Gearbox maintenance

2-cylinder engines gearbox is feeded with oil from engine oilsump. When engine is new or when changing oil, refill the

gearbox sump with fresh oil to prevent oil-level in engine sump from sinking under min. stroke, indicated on dip-stick. Refill with so much oil only, that clutch drum is touching oil-level. Use same oil as in engine.

1-cylinder engines' (models 50-KT, 36-A and EB) gearboxes are not fedded with oil from engine oil sump. By engine oil-changing, refill gearbox with fresh oil in the same way as for 2-cyl. engines.

Every (100) hour, lubricate models 36-A and EB in the following manner:

Remove gearbox shutter and set gearbox lever in »neutral» position. Turn the engine by hand until a brass-screw, situated on clutch-drum, will be seen. Remove the screw and press mixed grease-oil (60 % grease to 40 % oil) into drum by means of a grease-gun. Secure the screw.

If the gear slips by driving forward, do as follows:

Remove the gearbox shutter, set gearbox lever in »neutral» position. Turn the engine slowly by hand until a hexagon screw will be seen. The screw is situated on a tapered ironring, located between the strain clutches. The hexagon screw is securing the tapered ring. Set the gear-lever in »forward» position. Slacken the screw so much that the tapered ring will loosen. Set the gearbox lever in »neutral» position. Turn the ironring in a clockwise direction until the end of the securing screw fits in with the following groove in the bronze stop-plate and secure the screw. Try wether gear now is strained enough by setting the lever in »forward» position. Gear should be possible to connect by pushing only. If the first adjustment is not enough, proceed in the same way until correct adjustment is obtained. Secure the hexagon nut carefully.

If the gear slips by driving backwards, do as follows:

Right on the outside of gear-box you will find an adjusting-screw secured by a hexagon nut. Release the nut and turn the screw in a clockwise direction approximately $\frac{1}{2}$ turn. Usually

such an adjustment will be enough. Secure the screw carefully by means of the nut.

Localizing and repairing of damages

If the engine does not start normally this may be due to the following:

- The fuel- or airsupply gives trouble, for instance on account of clogged fuelpipes, pollution or water in the carburettor a. s. o. Control the fuelsupply. If this is normal, clean the carburettor.
- If the motor starts but the carburettor cracks, this is due either to a too poor gasmixture or sticking valves. Open the needlevalve more; if this does not help, the intake valves and the valve stemguides must be cleaned with kerosene and motoroil.
- Dirty, broken or wornout sparkplugs. Clean the sparkplugs and control the sparkgap, which should be 0,4—0,6 mm. Examine the non-conducting material of the sparkplugs; there must be no splits. Change sparkplugs after 300 running-hours to such ones, which have the same heating-value as the former.
- Magneto-damage. Burnt contact breaker points or a hanging contact breaker hammer. Loosen the lid of the magneto and control the contact breaker points. If these are burnt, trim with a file designed for that. Control the movement of the movable contact breaker point (hammer). If it runs stiffly, grease with care using thin motoroil. The point gap of the contact breaker should be 0,3—0,4 mm.
- Bad compression due to burnt or sticking valves, damaged cylindergasket, loosely tightened cylinderhead. Control the valveseats. Control the movement of the valves; the tappet clearance should be 0,3 mm for inlet valve, 0,4 mm

for outlet valve, the cylindergasket, tighten the screwnuts of the cylinderhead.

If the engine has been given sup after sup without starting, the sparkplugs are sour right through and it is impossible to start it. Proceed as follows:

Shut the needlevalve, screw of the sparkplugs and wind the engine quickly some 10 times. Pour motoroil through the sparkplug openings and rotate some turns; clean the sparkplugs and screw them on. After this start as usually.

Low effect

Low effect is usually due to some of the causes mentioned above, that is valve injury, sparkplug damage, wrong gas-mixture or wornout or pitchy pistonrings, wornout pistons, wornout cylinder bores. Even the following may be the cause:

- Too early or too late ignition. Too early ignition is noticed by knocks, too late by abnormal heat in the motor.
- Carbondeposits in combustion chamber, which causes knocking. Decarbonize the motor and thereafter control that the valves fit tight properly, sootflakes on the valveseats must be removed. If necessary grind seats and valves and lap in them in the artodox manner.
- The outlet pipe and the muffler choked up by carbon. Should be cleaned once every year, preferably in spring before the boat is put out.
- Too large a propeller or too high a pitch. The motor is working heavily with too low number of revolutions.

The engine stops while running

May be due to:

- Lack of fuel.

- Breakage on the airvalvespring in the carburettor or consumed leatherpacking (that applies to OLYMPIA carburettor).
- Choked up carburettor or water in the carburettor.
- Damage on the sparkplugs, magneto injury, breakdown on the magnetocable.
- Too much oil in the engine; the oil is thrown up on the sparkplugs.
- Highly worn pistons, pistonrings or cylinder bores with poor tightening and as a result oiled sparkplugs.

Guarantee- and delivery terms

We grant every new OLYMPIA-motor a guarantee for flaws in manufacture and material. The guarantee time is for 1 year counting from the day of delivery. During this time we pledge to make up for parts that have, as can be proved, become unfit for use on account of reasons above mentioned. The parts are delivered free on the following terms:

- The defective part have to be sent to us or our representative for supervision.
- If the damage causes repairing at a workshop, the motor should be sent to us or to our representative.
- The transport of the part or the motor to the factory, is done at the cost of the owner.

For all indirect injuries, of whatever kind they may be, which have been caused by injuries predicted in this guarantee, we are not responsible.

For repairs carried out by others without our leave we are not responsible.

Neither do we answer for damage caused by freezing, external injuries, overloading of the motor, neglected supervision or wrong management, poor lubricant, normal wear or other causes beyond our control.

For details as magneto, electrical equipment, sparkplugs, oil pressure gauges, taps, grease- and oilcups, gaskets a. s. o., not manufactured by us, we are not liable.

Attention! When ordering spare parts for the OLYMPIA-motors: state motornumber; refer to the enclosed printed drawings mentioning number of spare parts required.

FINSKA MOTORFABRIKS AB

V a s a



DIRUSTUS
RITNING
DRAWING N^o 110

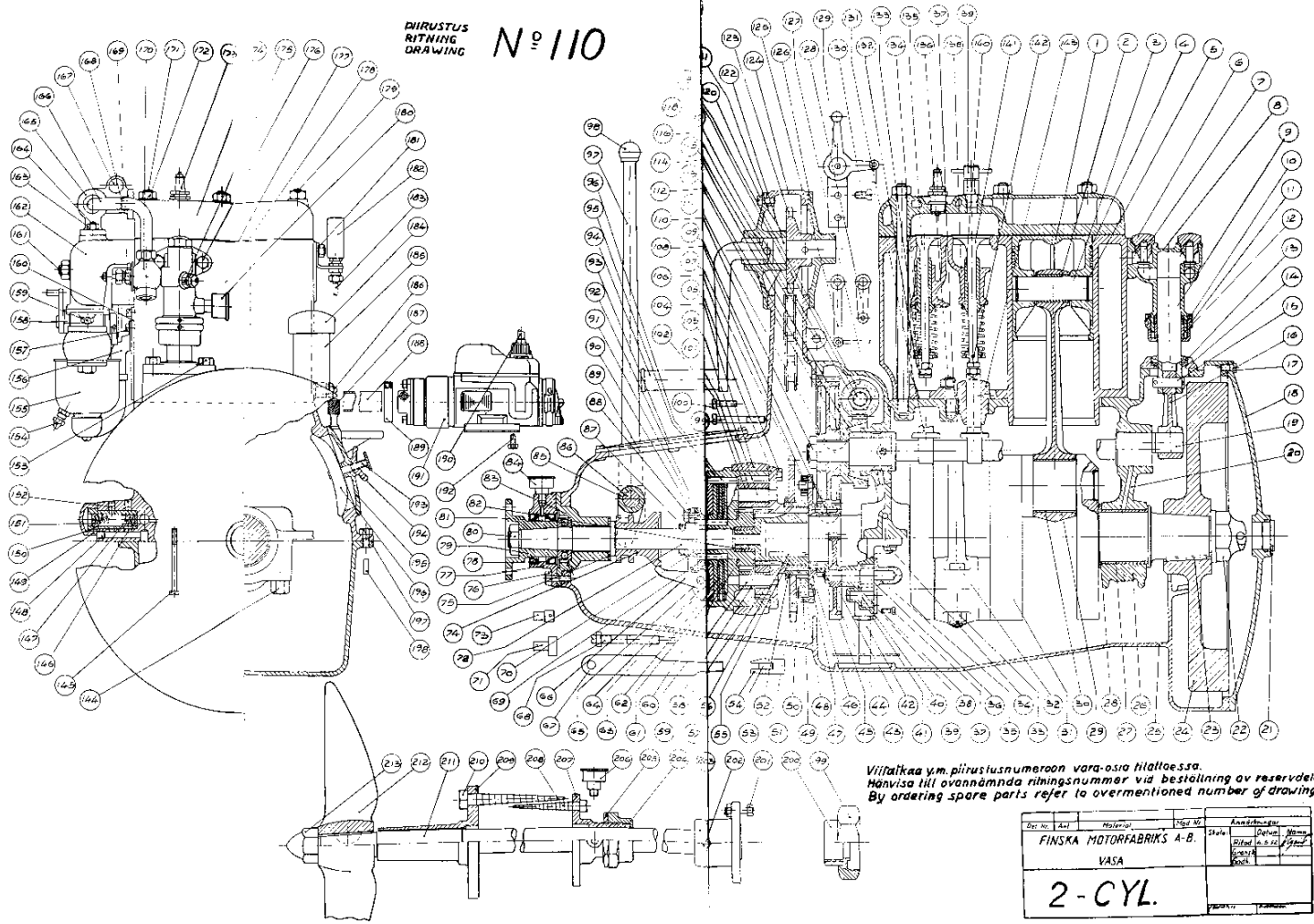

Viitalkaa ym. piirustusnumeroon vara-osia haittaessa.
Hänvisa till ovan nämnda ritningsnummer vid beställning av reservdelar.
By ordering spare parts refer to overmentioned number of drawing.

Doc. No.	Ään	Material	167 M	Ään	Ään
FINSKA MOTORFABRIKS A-B.				Ställe	Ställe
VASA				Ställe	Ställe
2-CYL.					